

MaxxECU

Notes:

Cables shields should only be grounded through the ECU.
Text in blue is the cable markings.

Digital input wiring

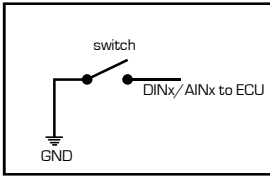

Sensor GND must **NEVER** be connected to chassis ground!

Wiring alternative for crank / home signal

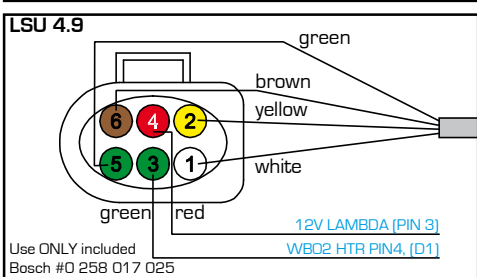
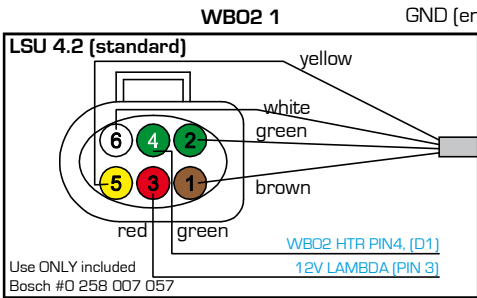
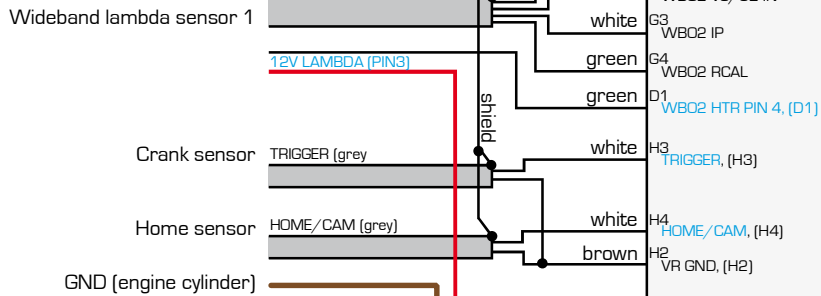
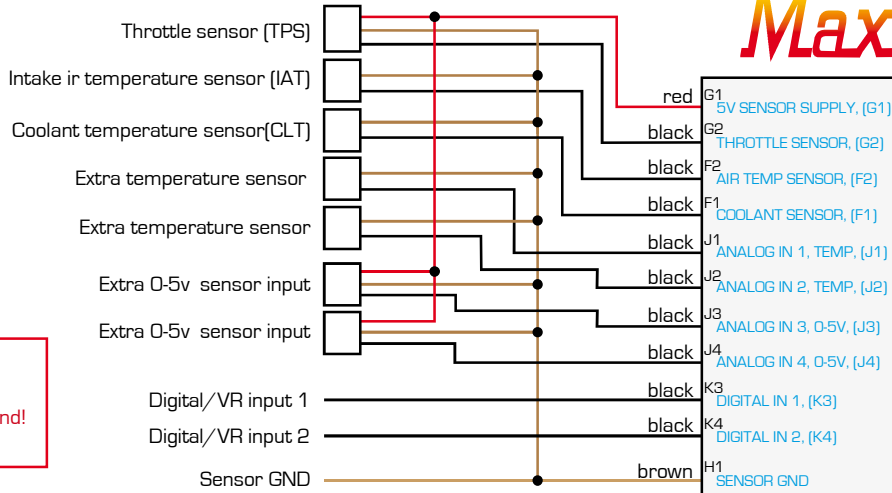
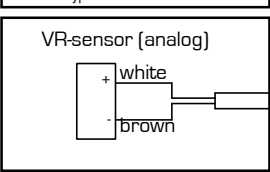
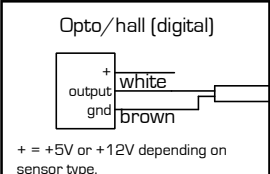

Available pins in connector uses as needed.
Small pin = max 15A
Big pin = max 25A

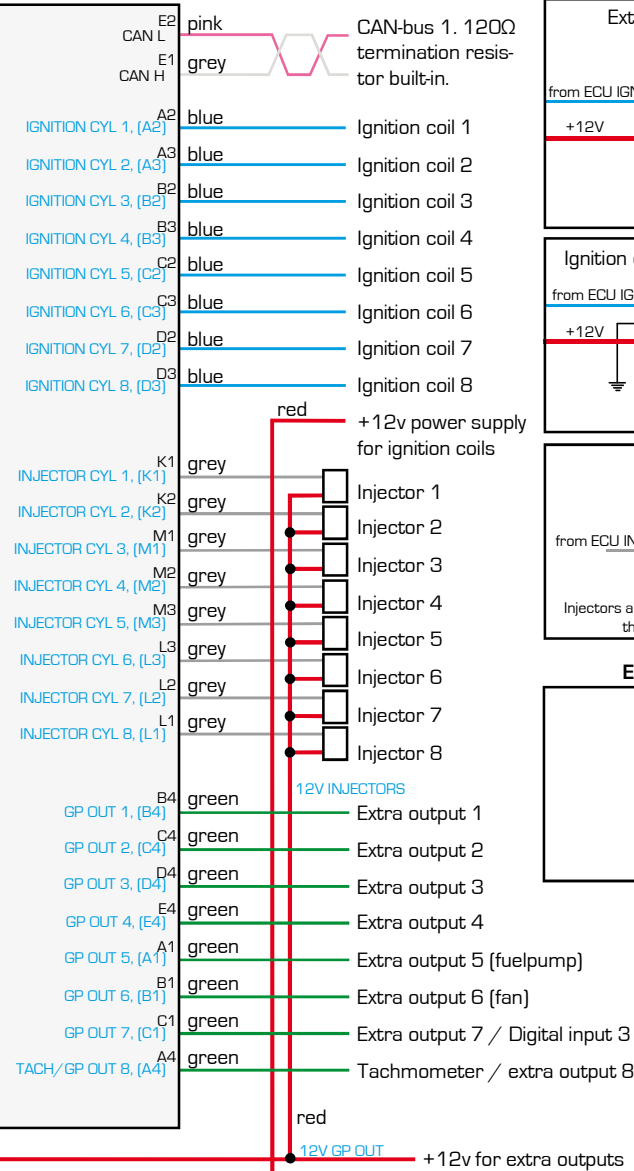

All GPO/INJ has 30V flyback as standard built-in

Options for connecting ignition coils

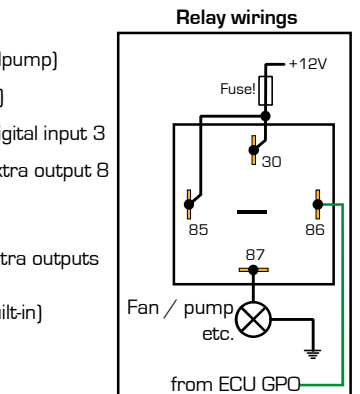
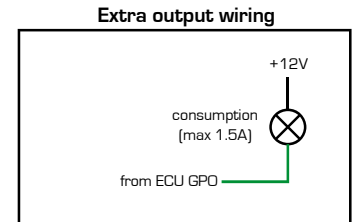
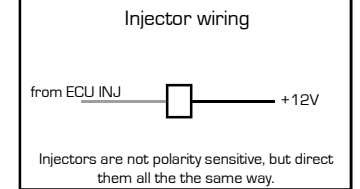
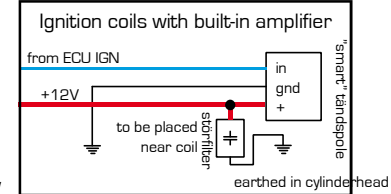
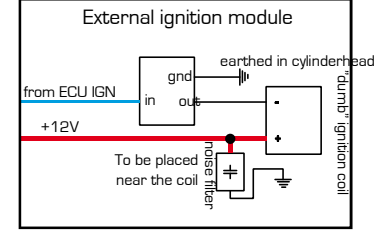

MaxxECU V1



MaxxECU PRO

MaxxECU

CMC	Label	Color
A1	EGT1+	Yellow
A2	EGT2+	Yellow
A3	EGT3+	Yellow
A4	EGT4+	Yellow
B1	EGT1-	Red
B2	EGT2-	Red
B3	EGT3-	Red
B4	EGT4-	Red
C1	EGT5+	Yellow
C2	EGT6+	Yellow
C3	EGT7+	Yellow
C4	EGT8+	Yellow
D1	EGT5-	Red
D2	EGT6-	Red
D3	EGT7-	Red
D4	EGT8-	Red
E1	EGT9+	Yellow
E2	EGT10+	Yellow
E3	EGT11+	Yellow
E4	EGT12+	Yellow
F1	EGT9-	Red
F2	EGT10-	Red
F3	EGT11-	Red
F4	EGT12-	Red
G1	-	-
G2	-	-
G3	-	-
G4	-	-
H1	ENGINE GROUND 3	Brown
H2	ENGINE GROUND 3	Brown
H3	ENGINE GROUND 3	Brown
H4	-	-

Connectors			Connectors		
ANSI Code	ANSI/ASTM E-230 Color Coding		IEC 584-3 Color Coding		IEC Code
	Thermocouple Grade	Extension Grade	Thermocouple Grade	Intrinsically Safe	
J					J
K					K
T					T
E					E
N					N

MaxxECU supported type

MaxxECU supported type



Use only Type K cables and connectors.

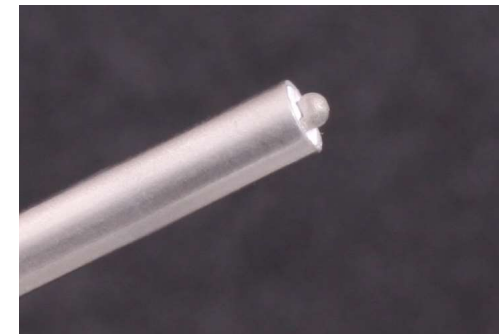

The tip of the sensor must be isolated from ground.



MaxxECU PRO
Connector 2

MaxxECU

Notes:

Cables shields should only be grounded through the ECU.
Text in blue is the cable markings.

Digital input wiring

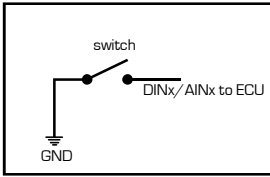

Wiring alternative for crank / home signal

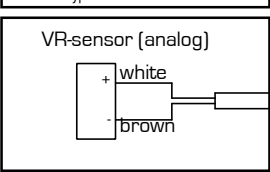
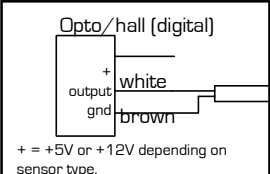

LSU connector seen from the cable side

WBO2 2

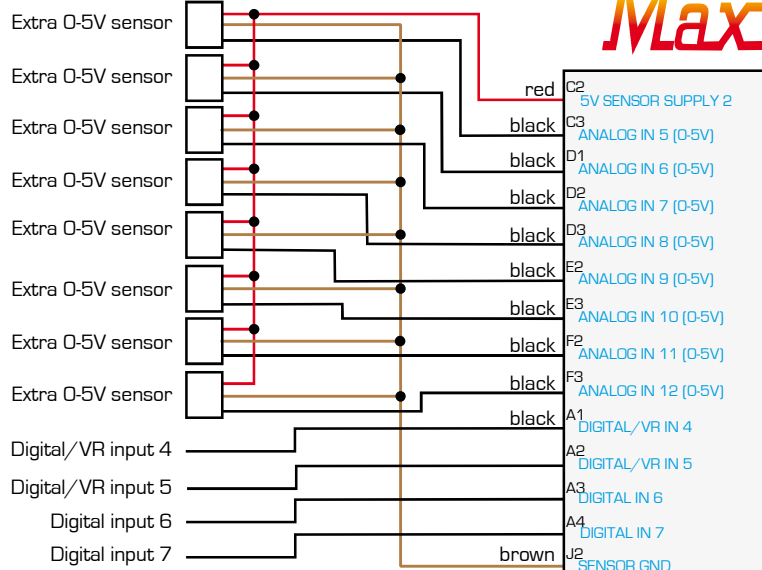
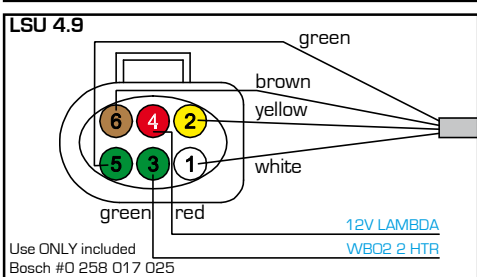
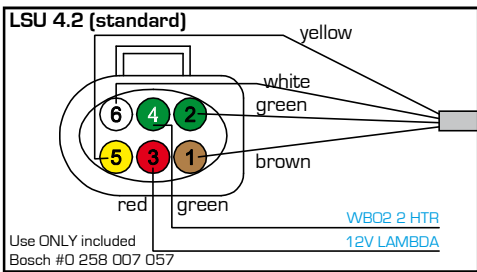

Sensor GND must **NEVER** be connected to chassis ground!

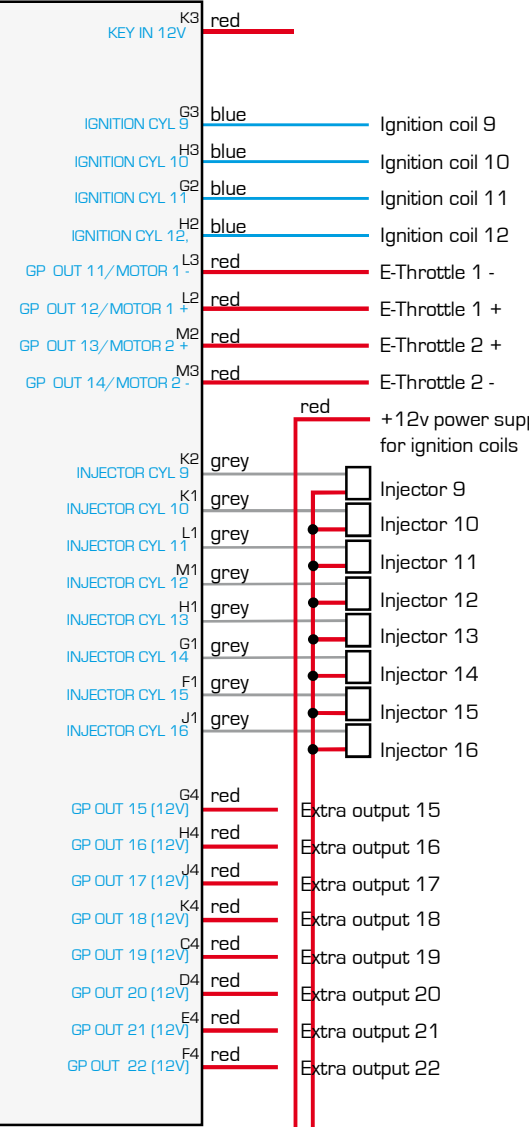
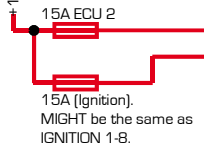
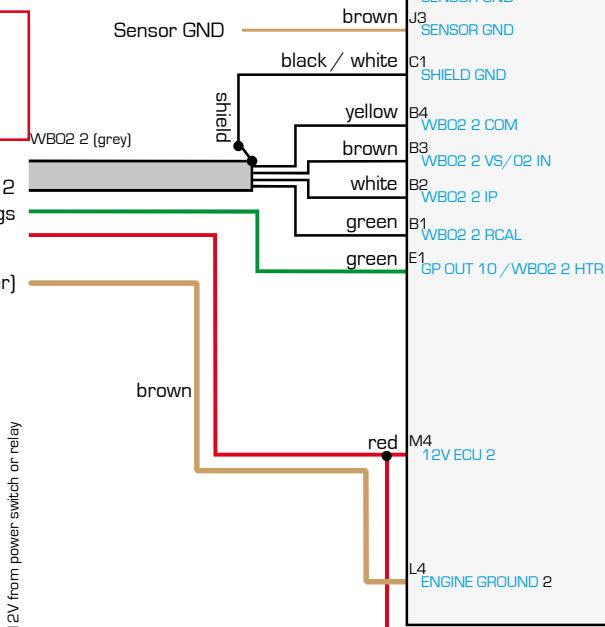

Options for connecting ignition coils

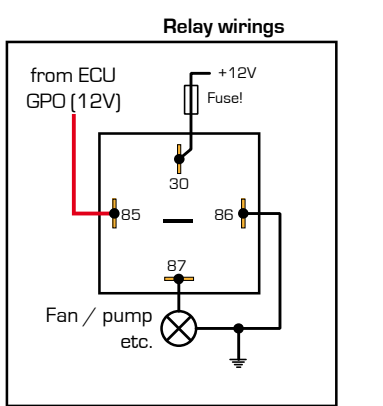
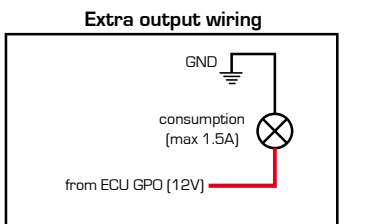
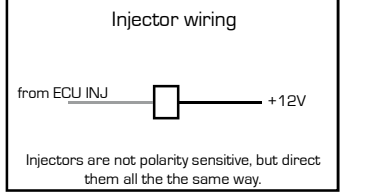
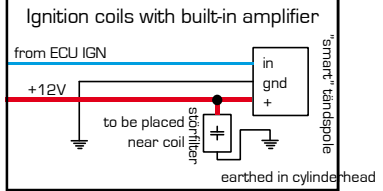
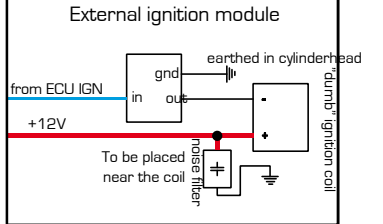

MaxxECU PRO Connector 3

Warning: Correct sensor must be selected in MTune before usage!

Notes:
 Cables shields should only be grounded through the ECU.
 Text in blue is the cable markings.

MaxxECU

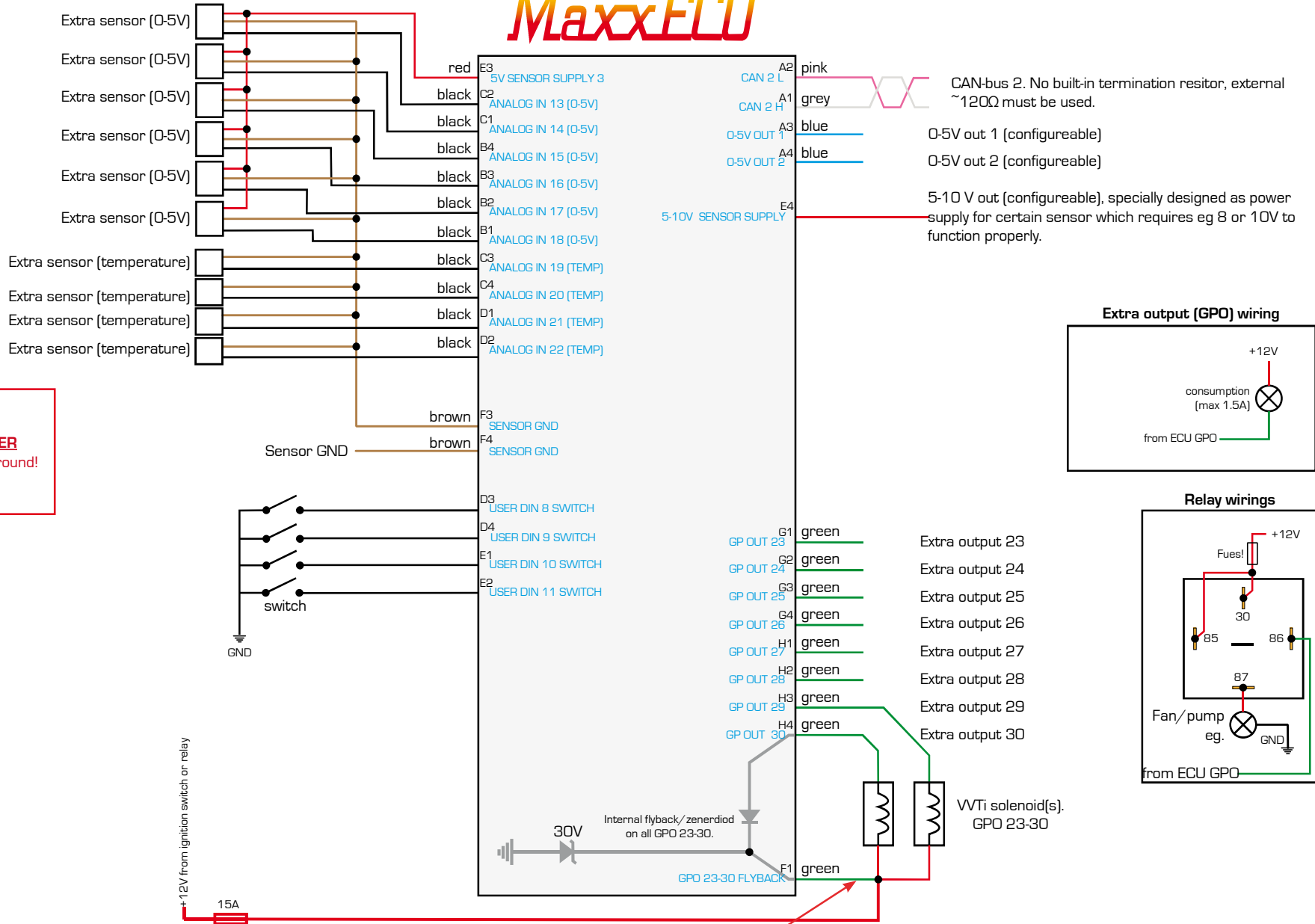

Sensor GND must **NEVER** be connected to chassie ground!

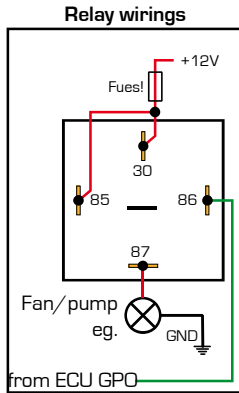
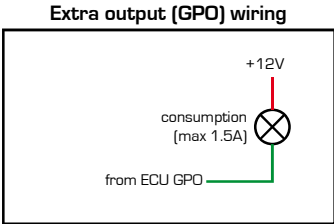

If the "GPO 23-30 FLYBACK" is NOT connected, the standard 30V internal flyback is used, which gives a faster response of the solenoids. To get 12V flyback on GPO 23-30, connect the F1 wire to the solenoid 12V power supply. This will result in slower movement of solenoids, suitable for some "floating" WTi solenoids.



MaxxECU PRO Connector 4